

2-PC INDUSTRIAL BALL VALVES EA-207A-SE

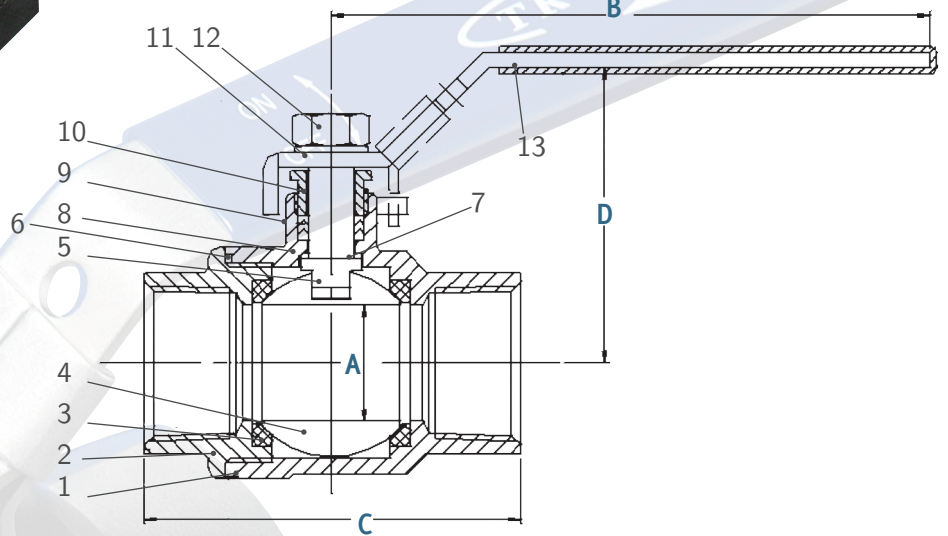

Features & Specifications

- » 2-piece 316 SS investment cast body
- » 1000 PSI WOG rating
- » Blowout proof stem design
- » Full ported design, NPT
- » Industrial/Chemical applications
- » Reinforced PTFE seat & seals
- » ANSI B16.34, ASTM A351
- » Available in 1/4"–2"



Size	A	B	C	D
1/4"	0.39	3.15	1.94	1.63
3/8"	0.49	3.15	1.94	1.63
1/2"	0.59	3.15	2.32	1.77
3/4"	0.79	3.94	2.70	2.15
1"	0.97	4.92	3.09	2.57
1 1/4"	1.26	4.92	3.67	2.79
1 1/2"	1.50	6.30	4.06	3.31
2"	1.97	6.30	4.85	3.67



Item	Part (Qty)	Material
1	Body	ASTM A351 GR CF8M
2	End Caps	ASTM A351 GR CF8M
3	Seats (2)	PTFE+15% G.F.
4	Ball	ASTM A351 GR CF8M
5	Stem	SS 316
6	Joint Gasket	PTFE
7	Gasket	PTFE
8	Seal	PTFE
9	Packing Gland	SS 304
10	Handle	SS 304
11	Lever Spring Washer	SS 304
12	Lever Nut	SS 304
13	Handle Cover	Vinyl