

DIRECT MOUNT EA-36-150-FE & EA-36-10



EA-36-10

Item	Part (Qty)	Material	
		A351 Gr. CG8M	A216 Gr. WCB
1	End Caps (3)	A351 Gr. CG8M	A216 Gr. WCB
2	Gasket (4)	PTFE	
3	Body	A351 Gr. CG8M	A216 Gr. WCB
4	Ball	SS 316	
5	Seat (4)	15% Carbon + PTFE	
6	Stem	SS 316	
7	Stem Seal	PTFE	
8	O-ring	VITON®	
9	Stem Packing	PTFE	
10	Gland	SS 304	
11	Belleville Washer (2)	SS 301	
12	Stem Nut	SS 304	
13	Nut Stop	SS 304	
14	Space Washer	SS 304	
15	Lock Saddle	SS 304	
16	Handle Nut	SS 304	
17	Handle	SS 304	
18	Handle Sleeve	Vinyl	
19	Stop Pin	SS 304	

*Available in NPT, socket-weld, and butt-weld ends

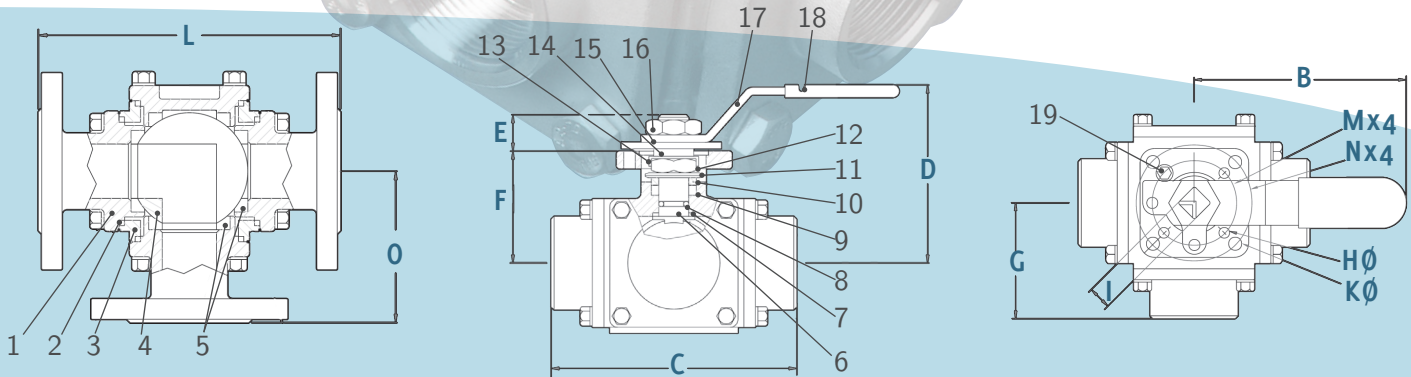

Size	B	C	D	E	F	G	H	I	K	L	M	N	O	ISO5211
¼	5.12	3.46	2.44	0.39	1.52	1.73	1.65	0.35	1.42	3.46	0.24	0.24	1.73	F03/F04
⅜	5.12	3.46	2.44	0.39	1.52	1.73	1.65	0.35	1.42	3.46	0.24	0.24	1.73	F03/F04
½	5.12	4.12	2.52	0.39	1.61	2.07	1.65	0.35	1.42	3.59	0.24	0.24	1.80	F03/F04
¾	6.50	4.41	3.23	0.51	1.93	2.07	1.97	0.43	1.65	4.41	0.28	0.24	2.21	F04/F05
1	6.50	5.04	3.50	0.51	2.17	2.76	1.97	0.43	1.65	5.04	0.28	0.24	2.52	F04/F05
1¼	8.07	5.51	3.86	0.67	2.48	2.52	2.76	0.55	1.97	5.51	0.36	0.28	2.76	F05/F07
1½	8.07	6.30	4.25	0.67	2.91	3.15	2.76	0.55	1.97	6.30	0.36	0.28	3.15	F05/F07
2	12.80	7.56	5.51	0.87	3.66	3.78	4.02	0.67	2.76	7.56	0.45	0.36	3.78	F07/F10
2½	15.75	11.57	5.67	0.98	4.66	5.78	-	0.87	4.00	11.57	0.67	0.45	5.79	F10
3	19.69	12.48	6.38	0.98	5.37	6.24	-	0.87	4.00	12.48	0.67	0.45	6.24	F10
4	25.59	14.53	7.17	0.98	6.16	7.27	-	0.87	4.00	14.53	0.67	0.45	7.27	F10