

# MULTI-PORT SERIES INDUSTRIAL BALL VALVE

## Features & Specifications

- » ASTM 316 grade stainless steel
- » 150# and 300# ANSI flanged ends available
- » Live loaded stem packing
- » Full port L or T port design, also available in 4-way option
- » Direct mounting ISO 5211 mounting pad
- » Investment cast and sand cast body construction
- » Meets international standards
- » Cost effective solution by reducing amount of valves needed in system
- » 1000 PSI WOG
- » ½"–8" size range



EA-36-150-FE

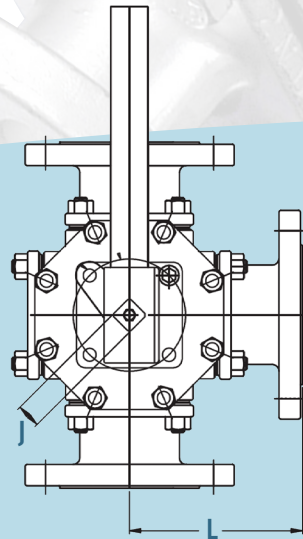
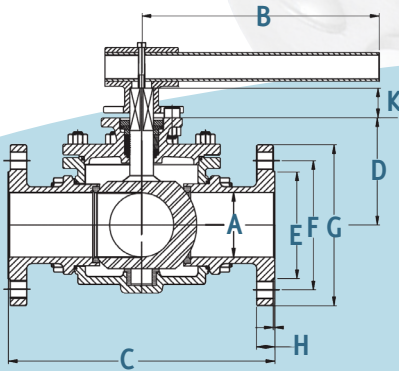

Size	A	B	C	D	E	F	G	H	J (mm)	K (mm)	L	ISO5211
½	0.59	5.12	5.98	1.61	1.38	2.38	3.50	0.44	9	11	2.99	F03/F04
¾	0.79	6.50	6.57	1.93	1.69	2.76	3.86	0.44	11	14	3.29	F04/F05
1	0.98	6.50	7.48	2.17	2.01	3.13	4.25	0.44	11	14	3.74	F04/F05
1¼	1.26	8.07	8.19	2.48	2.52	3.50	4.61	0.50	14	18	4.10	F05/F07
1½	1.50	8.07	8.66	2.91	2.87	3.88	5.00	0.56	14	18	4.33	F05/F07
2	1.97	12.80	9.96	3.66	3.62	4.74	5.98	0.62	17	23	4.98	F07/F10
2½	2.44	15.75	11.81	4.67	4.13	5.49	7.01	0.70	22	25	5.91	F10
3	2.99	19.69	12.01	5.37	5.00	6.00	7.48	0.75	22	25	6.01	F10
4	3.78	25.59	14.51	6.16	6.18	7.50	9.02	0.94	22	25	7.26	F10
6	5.91	47.24	16.81	6.28	8.50	9.51	11.00	1.00	36	36	8.41	F12

L-Port

T-Port

